

By Jerry Bisbee – ATC Tech Trainer

Troubleshooting ICUF Instrument Clusters

Late model FLD Freightliners are equipped with Ametek Dixson Next Generation Instrumentation (NGI) gauge systems. The Freightliner name for this system is ICUF. The ICUF system uses the speedometer as the central controller that controls the gauges that are part of the ICUF system. The speedometer receives engine information via the J-1587 databus along with information it receives from the fuel level sensor, axle temperature sensors, and transmission temperature sensor. The speedometer processes this information

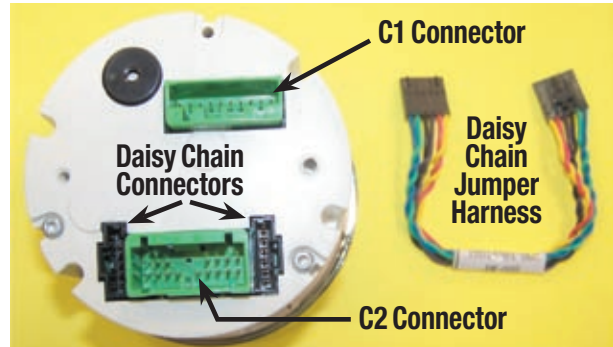

Figure 1 – ICUF Speedometer Rear View

and sends it out to the other gauges via six-wire “daisy chain” jumper harnesses (see Figure 1). The speedometer is equipped with four connectors, connector C1, connector C2, and two “daisy chain” connectors (see Figure 1). Each of the other gauges has two “daisy chain” connectors that connect the gauges to each other. The “daisy chain” jumper harnesses furnish power, ground, backlighting power, and proprietary datalink information from the speedometer to each gauge. Figure 2 illustrates the pinouts of the four connectors located on the back of the speedometer. J-1587 databus information from the engine ECU is used by the speedometer to display vehicle speed, engine speed, oil pressure, coolant temperature, engine oil temperature, boost pressure and voltage.

Testing Gauge Function

The ICUF speedometer is equipped with two switches; the MODE switch and the SET switch, which are used to scroll through information menus on the speedometer’s message display (see Figure 3). These switches are located at the bottom of the speedometer face. They may also be used to perform diagnostics on the gauges.

Using the Automatic Mode Test Procedure

1. Turn ignition switch on.
2. Using the MODE switch scroll until **DIAGST** is displayed in the display window.
3. Press the SET switch to enter the test mode.
4. Press the mode switch to scroll between **AUTO**, **MANUAL**, and **EXIT**.
5. When **AUTO** is displayed press the SET switch to start the auto test.
6. The gauges and warning LEDs on the gauges that are part of the ICUF system will function in the following manner with a corresponding message on the display. Verify that the gauges and LEDs function as follows:
 - **MIN**—All gauge pointers go to zero scale. All warning LEDs are off.
 - **MID**—All gauge pointers go to mid-scale. All warning LEDs are off.
 - **MAX**—All gauge pointers go to full-scale. All warning LEDs are off.
 - **LED**—All gauge pointers go to zero scale. All warning LEDs are on.
7. When the test is complete push the SET or MODE switch to stop the test.
8. Use the MODE switch to scroll until **EXIT** appears.
9. If any of the ICUF controlled gauges fails to function according to the test, the gauge may be tested individually by using the manual test procedure.

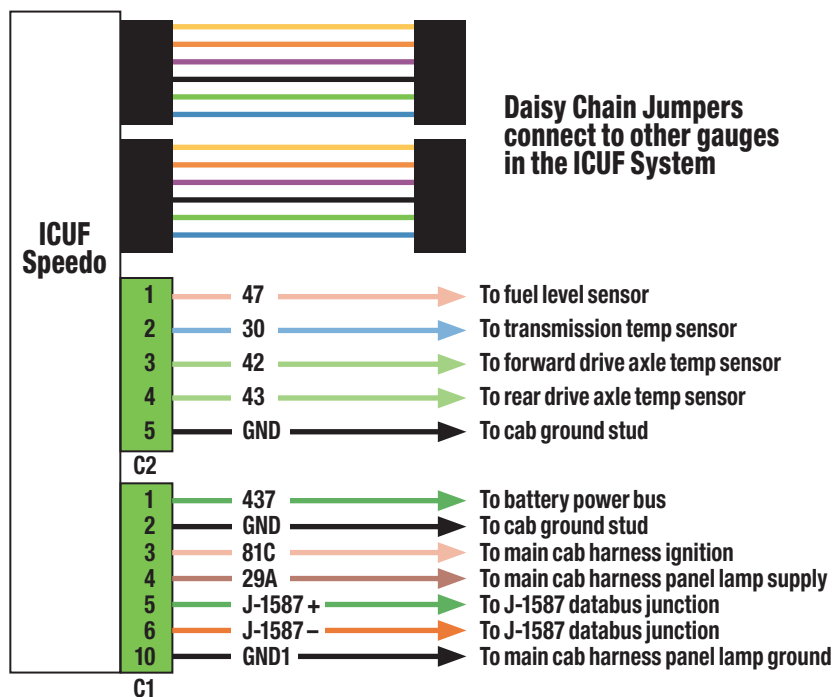

Figure 2 – ICUF Speedometer Pinouts

Using the Manual Mode Test Procedure

Follow the Automatic Mode procedure above through step 4. Follow the rest of the procedure below.

5. When **MANUAL** is displayed press the SET switch.
6. To test a gauge:
 - 6.1 Press the MODE switch to scroll through the menu until the name of the gauge you wish to test is displayed.
 - 6.2 Press the SET switch to enable the test for the selected gauge.
 - 6.3 Verify that the gauge behaves as follows:
 - **MIN** – The gauge pointer goes to zero scale and its warning LED is off.
 - **MID** – The gauge pointer goes to mid-scale and its warning LED is off.
 - **MAX** – The gauge pointer goes to full scale and its warning LED is off.
 - **LED** – The gauge pointer goes to zero scale and its warning LED is on.
 - 6.4 Press the MODE switch to exit the gauge test.
 - 6.5 Continue pressing the MODE switch until **EXIT** appears.
 - 6.6 Press the SET switch to exit the manual mode and return to normal operation.

If the gauge operates correctly according to these test procedures, but doesn’t correctly display information the problem is either the speedometer is not receiving information used to drive the gauge, or the speedometer is faulty.

Testing Information for Gauges that Display Engine Information

To test for this condition on gauges that display information sent from the engine, connect the service tool used to read the engine information, or connect Servicelink to the truck’s diagnostic connector. Check to see if the engine ECU is broadcasting the information for the gauge. If it is not, the problem is in the engine sensor, engine harness, or engine ECU. If the information for the gauge you are testing is being broadcast, but the gauge is not displaying it the problem is with the speedometer.



Mode Switch Set Switch
Figure 3 – ICUF Speedometer Switches

Testing Information for Gauges that Do Not Display Engine Information

The fuel level gauge, transmission temperature gauge, and axle temperature gauges are driven by the speedometer using information from sensors wired to the speedometer. These sensors are wired to connector C2 at the speedometer (see Figure 1).

- To test the fuel level sensor and wiring, remove the connector at the fuel level sensor. Connect a 250 ohm resistor across the two pins in the harness connector. Turn the key on and view the fuel level gauge. The gauge should read **EMPTY**. Remove the 250 ohm resistor and connect a 30 ohm resistor across the pins. The gauge should read **FULL**. If the gauge works correctly according to these tests, replace the fuel level sensor. If the gauge still doesn’t work, turn the ignition off and disconnect the truck’s batteries. Remove the C2 connector from the speedometer. Use an ohmmeter to measure the resistance between pins 1 and 5. The resistance should be approximately 30 ohms with the 30 ohm resistor still connected across the fuel level sensor connector. If the resistance value is correct replace the speedometer. If the resistance value is not correct, test the wiring between the speedometer and the sensor. Also test the ground wire from the sensor connector to the frame ground.
- To test the transmission temperature sensor or axle temperature sensor follow the procedure above except for the following:

With the temperature sensor disconnected, connect a 6000 ohm resistor across the two pins. With the key on, the temperature gauge should read 100°F (minimum scale). Remove the 6000 ohm resistor and connect a 190 ohm resistor between the pins on an axle temperature sensor or a 115 ohm resistor between the pins on a transmission temperature sensor. The appropriate gauge should read full scale. If the gauge works according to these tests, replace the sensor. If the gauge doesn’t work test the wiring between the sensor and speedometer, and the ground wire between the sensor and the frame ground. Refer to Figure 2 for the correct pinouts for these tests.

wheels & deals

Wheels & deals is a monthly newsletter published by T.E.A.M., Inc. for The Around the Clock Freightliner Group, LLC. Subscriptions are free and can be requested by calling 1.800.999.6511 or emailing us at: team7300@atcfreightliner.com. All rights reserved. Any use of the contents of this publication without the express written consent of the publisher is strictly prohibited.

Editorial Committee

<p>Paul Burk General Manager - Fort Worth</p> <p>Don Freeman General Manager - Tulsa</p> <p>Jim King General Manager - Service</p>	<p>Bob Acker General Manager - Dallas</p> <p>Doug Phillips Center Manager - Select Trucks of Dallas</p> <p>Robert Thompson General Manager - Parts</p>	<p>Cassie Bowen Editor in chief - T.E.A.M., Inc.</p> <p>Shannon Evans Managing Editor - T.E.A.M., Inc.</p> <p>Paul Evans EvansDesign</p>
---	---	---